

GERADE T-STÜCKE FÜR ENTLÜFTUNGEN / ENTLEERUNGEN

SERIE 1

ABZWEIGROHR		d2	25	32	40	50	L
		D2	90	110	110	125	
DURCHGANGSROHR							
d1	D1						
32	110	H	500				900
40	110	H	500				
50	125	H	500	500	500		
65	140	H	500	500	500	550	1000
80	160	H	550	550	550	600	
100	200	H	550	550	550	600	1100
125	225	H	550	550	550	600	
150	250	H	550	550	550	600	
200	315	H	600	600	600	650	1200
250	400	H	600	600	600	650	1400
300	450	H	650	650	650	700	1500
350	500	H	650	650	650	700	
400	560	H	700	700	700	750	1600
450	630	H	700	700	700	750	1800
500	710	H	750	750	750	800	1900
600	800	H	750	750	750	800	2000

*Alle in den Tabellen angegebenen Dimensionen sind in Millimetern ausgedruckt.

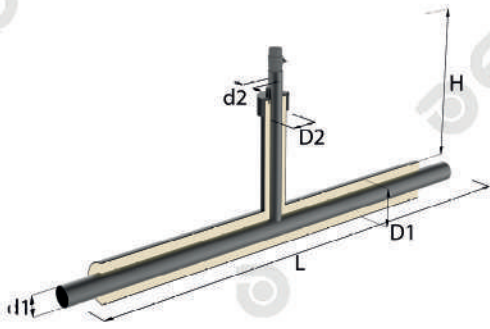

GERADE T-STÜCKE FÜR ENTLÜFTUNGEN / ENTLEERUNGEN

SERIE 2

ABZWEIGROHR		d2	25	32	40	50	L
		D2	110	125	125	140	
DURCHGANGSROHR							
d1	D1						
32	125	H	500				900
40	125	H	500	500	500		
50	140	H	500	500	500	550	
65	160	H	500	500	500	550	1000
80	180	H	550	550	550	600	
100	225	H	550	550	550	600	1100
125	250	H	550	550	550	600	
150	280	H	550	550	550	600	1200
200	355	H	600	600	600	650	
250	450	H	600	600	600	650	1400
300	500	H	650	650	650	700	
350	560	H	650	650	650	700	1500
400	560	H	700	700	700	750	
450	630	H	700	700	700	750	1800
500	710	H	750	750	750	800	
600	800	H	750	750	750	800	2000

*Alle in den Tabellen angegebenen Dimensionen sind in Millimetern ausgedruckt.

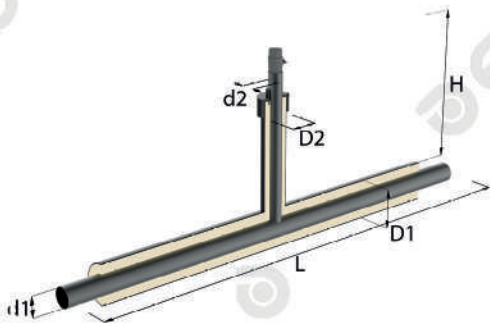

GERADE T-STÜCKE FÜR ENTLÜFTUNGEN / ENTLEERUNGEN

SERIE 3

ABZWEIGROHR		d2	25	32	40	50	L
		D2	125	140	140	160	
DURCHGANGSROHR							
d1	D1						
25	125	H	500	500	500		900
32	140	H	500	500	500		
40	140	H	500	500	500		
50	160	H	500	500	500	550	
65	180	H	500	500	500	550	1000
80	200	H	550	550	550	600	
100	250	H	550	550	550	600	1100
125	280	H	550	550	550	600	
150	315	H	550	550	550	600	
200	400	H	600	600	600	650	1200
250	500	H	600	600	600	650	1400
300	560	H	650	650	650	700	1500
350	630	H	650	650	650	700	
400	560	H	700	700	700	750	1600
450	630	H	700	700	700	750	1800
500	710	H	750	750	750	800	1900
600	800	H	750	750	750	800	2000

*Alle in den Tabellen angegebenen Dimensionen sind in Millimetern ausgedruckt.