

## PARALLELE T-STÜCKE



### SERIE 2

ABZWEIGROHR	d2	20	25	32	40	50	65	80	100
	D2	110	110	125	125	140	160	180	225

DURCHGANGSROHR										
d1	D1	H								
20	110	H								
25	110	H		270						
32	125	H		280	285					
40	125	H		280	285	285				
50	140	H		285	295	295	310			
65	160	H		265	270	270	315	335		
80	180	H		290	290	290	330	350	380	
100	225	H		305	310	310	345	365	395	350
125	250	H		320	325	325	355	375	410	370
150	280	H		340	335	335	370	390	425	390
200	355	H		365	375	375	395	415	450	425
250	450	H		420	425	425	435	445	475	470
300	500	H		445	450	450	560	470	500	500
350	560	H		475	480	480	490	500	520	530
400	630	H								
450	710	H								
500	800	H								
600	900	H								

\*Alle in den Tabellen angegebenen Dimensionen sind in Millimetern ausgedruckt

# PARALLELE T-STÜCKE

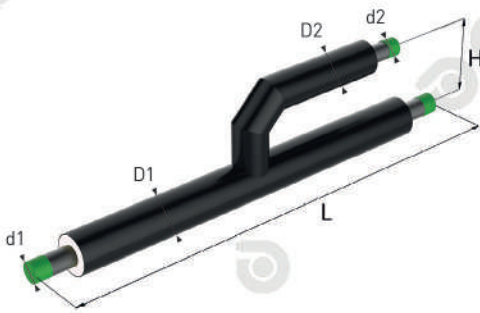

## SERIE 2

ABZWEIGROHR	125	150	200	250	300	350	400	450	500	600	L
	225	250	315	400	450	500	560	630	710	800	

DURCHGANGSROHR													
d1	D1												
20	110												
25	110												
32	125												
40	125												
50	140												
65	160												
80	180												
100	225												
125	250	385										900	
150	280	395	410									1000	
200	355	430	445	485							1100		
250	450	500	520	560	595						1200		
300	500	515	525	580	620	710					1400		
350	560	545	560	600	640	730	810				1500		
400	630		600	630	680	710	840	915			1600		
450	710		635	670	720	745	860	960	1030			1800	
500	800			720	770	790	890	970	1060	1150			1900
600	900				820	840	940	1020	1110	1200	1350	2000	

\*Alle in den Tabellen angegebenen Dimensionen sind in Millimetern ausgedruckt